

GV-IO Box 16 Ports

The GV-IO Box 16 provides 16 inputs and 16 relay outputs. It supports both DC and AC output voltages, and provides a USB port for PC connection.

Features

- ❶ 16 inputs and 16 outputs are provided.
- ❷ Up to 9 pieces of GV-IO Box 16 can be chained together.
- ❸ A USB port for PC connection is only used for 30 DC output voltage.

Packing List

- ❶ GV-IO Box 16 x 1
- ❷ USB Cable (Type A to B) x 1
- ❸ Power Adaptor DC 12V x 1
- ❹ Terminal Resistor x 1
- ❺ Installation Guide x 1

Specifications

Compatible S/W	GV-System version 8.2 or above			
Input	Input	16		
	Input Signal	Dry Contact Wet Contact, 9-30V AC/DC		
Output	Relay Output	16		
	Relay Status	Normal Open		
	Relay Capacitance	USB Connection	30V DC, 3A	
		RS-485 Connection	125 / 250V AC, 3A 30V DC, 3A	
DC IN	DC 12V, 1A			
Address	0-9, A-F			
Terminal Resistance	120Ω			
Environmental Conditions	0 ~ 50 degree C / 32 ~ 122 degree F 5% ~ 95% (non-condensing)			
Dimensions (W x H x D)	180 x 27 x 183 mm / 7.09 x 1.06 x 7.2 in			

Overview

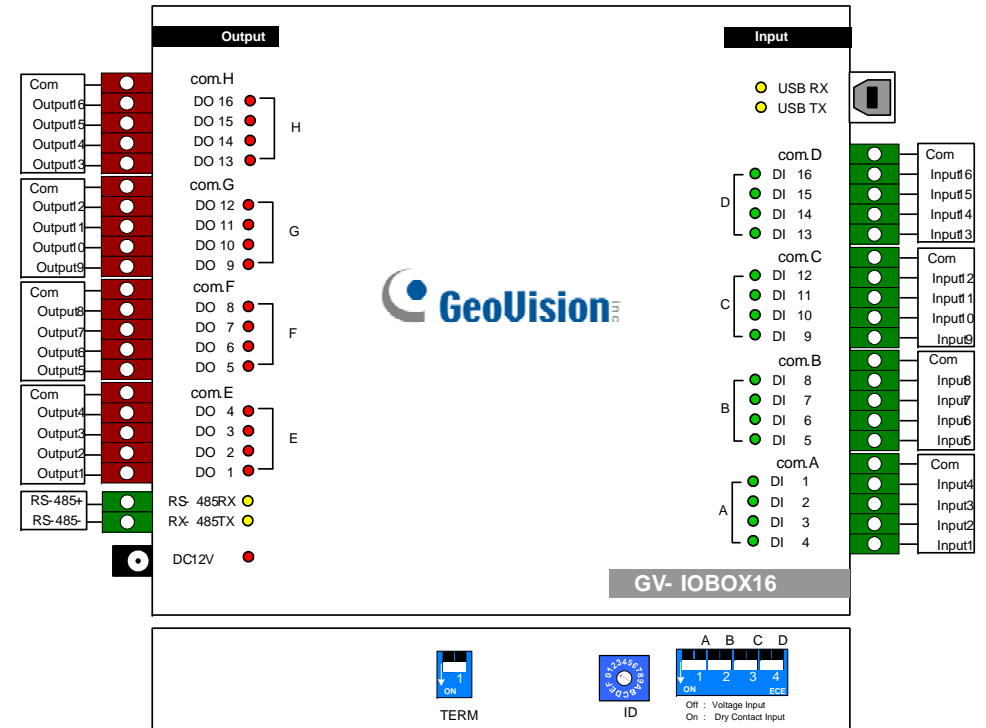

DIP Switch

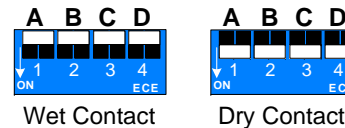

The GV-IO Box 16 allows the use of mixing dry and wet contact devices together. The 16 inputs divided as four-in-one groups (A, B, C and D) are related to the 4 switches on the box for dry and wet contact.

To change the inputs to different kind of contact, push the switch upward (wet contact) or downward (dry contact).

Note: The RS-485 connectors do not have the conversion function from RS-485 to RS-232. The GV-IO Box 16 will not work if you connect RS-485 devices, such as PTZ camera, to the connectors.

Connections to PC

There are two ways to connect the GV-IO Box 16 to the PC:

- (1) Use the USB cable to connect to the PC, and
- (2) Through the option of GV-Hub, GV-COM, GV-NET Card or GV-NET/IO Card, use the RS-485 connectors to connect with the PC.

1. Use the USB cable to connect one GV-IO Box 16 to PC.

(Allowed for DC Output Voltage only)

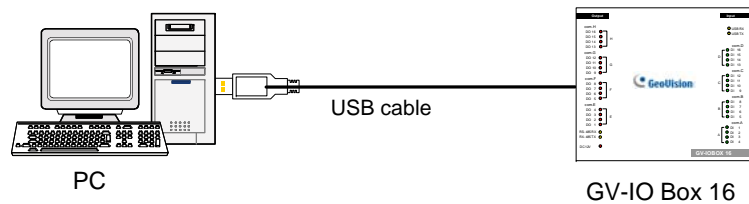

Note: It is required to install the USB driver. See *USB Driver Installation* later in this document.

2. Use the RS-485 connectors to connect one GV-IO Box 16 to PC.

(Allowed for AC/DC Output Voltage)

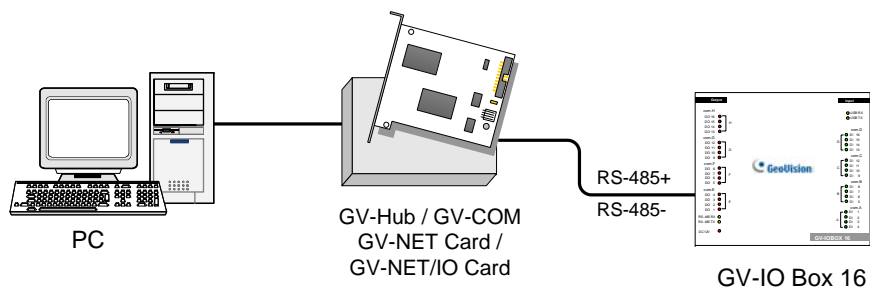

Assigning Addresses to GV-IO Box 16

Up to 9 pieces of GV-IO Box 16 can be chained together to expand the I/O capacity. Use the ID Switch to assign addresses 1~9 to the connected GV-IO Box 16.

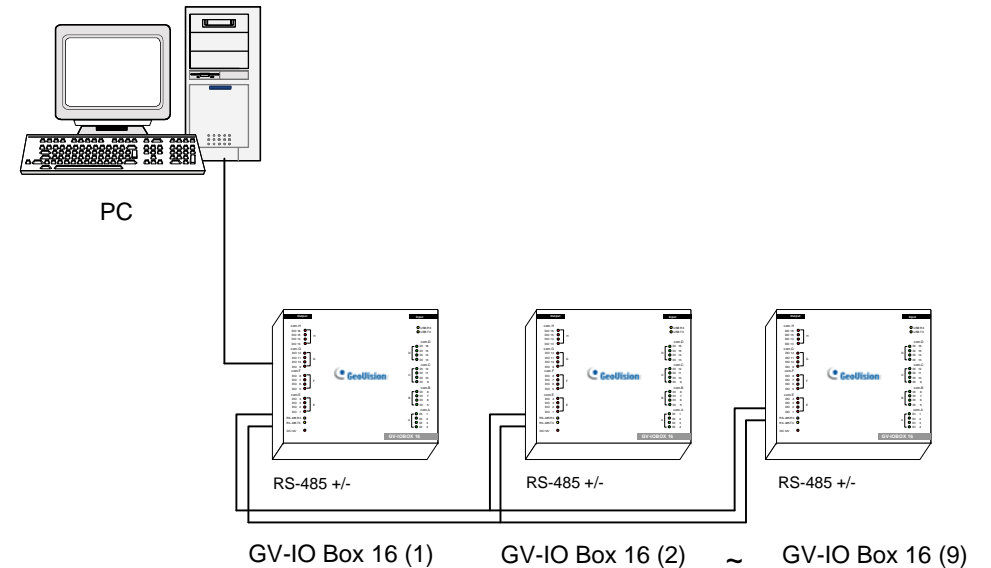

ID Switch

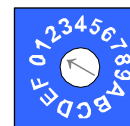

ID

1. **Addresses 0 and A to F** are NOT functional.
2. Assign the addresses when the power is off.
3. If you want to change the assigned address of the connected GV-IO Box 16, set the switch to the new address, and then re-plug the power adaptor.

Long-Distance Connections

It is required to switch on the Terminal Resistance Switches when the connection distance is longer than 200 meters (656.16 feet). Three conditions below illustrate how the Terminal Resistance Switches should be switched on.

1. Multiple pieces of GV-IO Box 16 are connected with the PC through one single RS-485 cable.

If you connect multiple pieces of GV-IO Box 16 with the PC, only switch on the Terminal Resistance Switches in the first and last connected pieces of GV-IO Box 16.

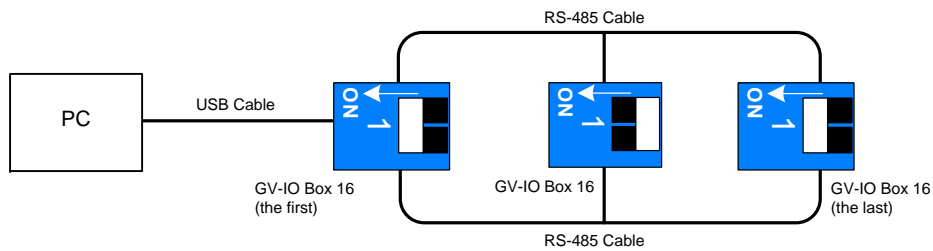

2. Multiple pieces of GV-IO Box 16 are connected with the PC through a RS-485 / RS-232 conversion device.

If you connect multiple pieces of GV-IO Box 16 with the PC through a RS-485 / RS-232 conversion device, such as GV-NET/IO Card and GV-Hub, insert a Terminal Resistor in the conversion device and switch on the Terminal Resistance Switch of the last connected GV-IO Box 16.

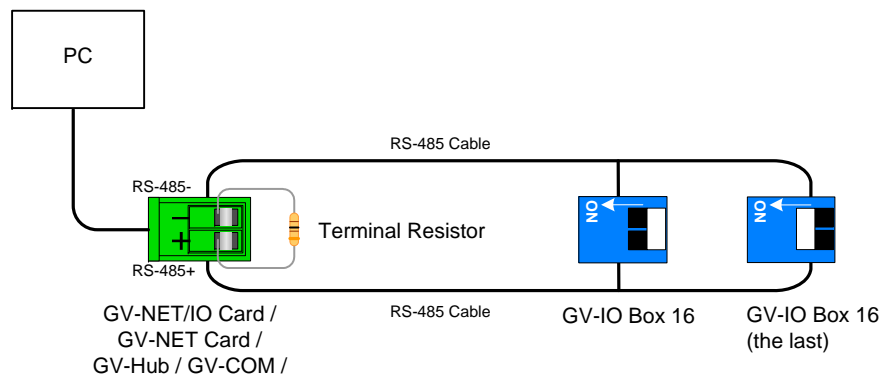

3. Multiple pieces of GV-IO Box 16 are connected with the PC through separate RS-485 cables.

If you connect multiple pieces of GV-IO Box 16 with the PC through separate RS-485 cables, switch on Terminal Resistance Switches of the connected piece of GV-IO Box 16 at the end of each cable.

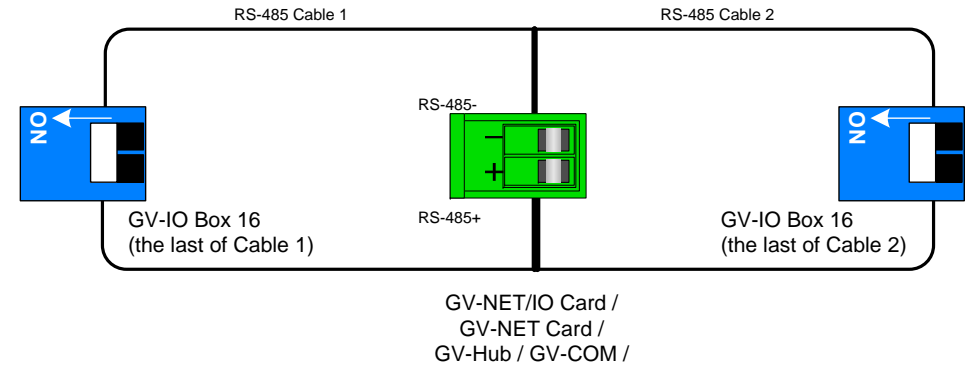

Terminal Resistance Switch

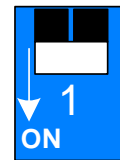

To switch on the Terminal Resistance Switch, push the switch downward.

USB Driver Installation

To use the USB function, it is required to install the driver on the PC. Follow these steps to install the driver:

1. Insert the software DVD. It will run automatically and pop up a window.
2. Select **Install or Remove GeoVision GV-Series Driver**, and then click **Install GeoVision USB Device Drivers**. This dialog box appears.



3. Click **Install** to install the drivers. When the installation is complete, this message will appear: *Install done!*
4. Click **Exit** to close the dialog box.
5. To verify the drivers are installed correctly, go to Device Manager. Expanding the Ports field, you should see one entry for Prolific USB-to-Serial Bridge.

